

KONTRAKTSVEDLEGG  
TORGKVARTALET HUS 6

Fasade nordvest og sørvest



Parkeringsgarasje

Fasade nordvest



Fasade sørvest

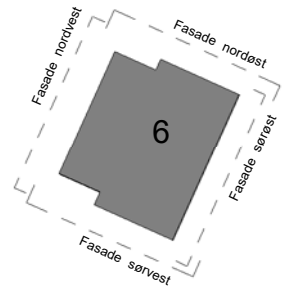

08/10/18

DOKUMENT GYLDIG: .....

GODKJENT: .....

KONTRAKTSDATO: .....

SELGER: .....

KJØPER: .....

KONTRAKTSVEDLEGG  
TORGKVARTALET HUS 6

Fasade nordøst og sørøst



Fasade nordøst

Parkeringsgarasje

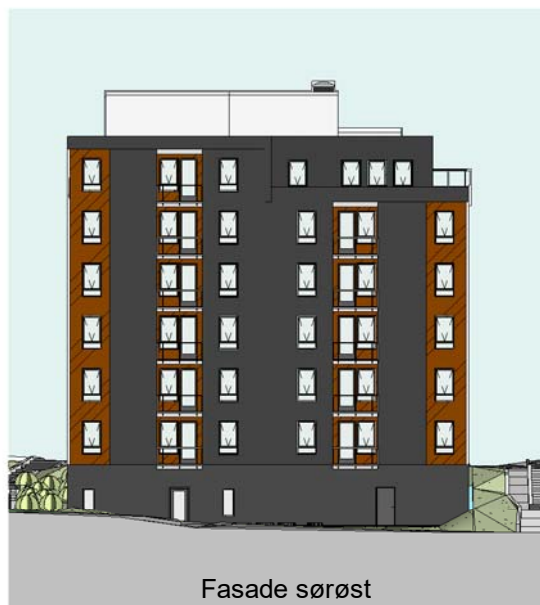

Fasade sørøst

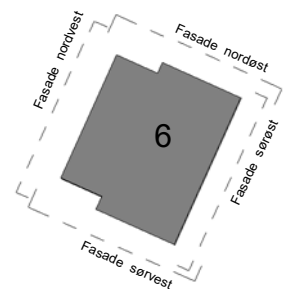

08/10/18

DOKUMENT GYLDIG: .....

GODKJENT: .....

KONTRAKTSDATO: .....

SELGER: .....

KJØPER: .....

KONTRAKTSVEDLEGG  
TORGKVARTALET HUS 6

SNITT

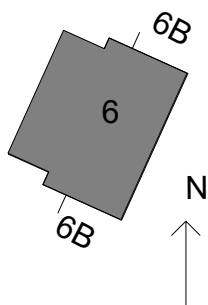
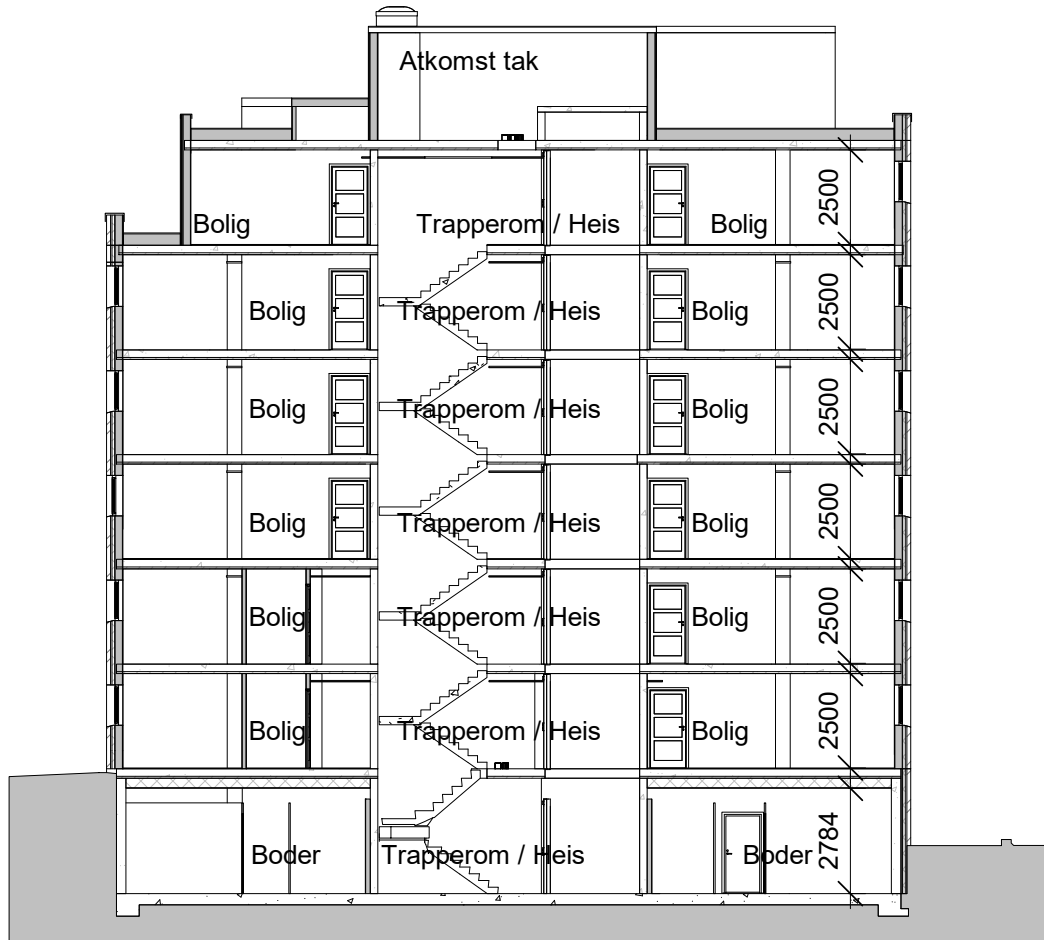

08/10/18

DOKUMENT GYLDIG: .....

KONTRAKTSDATO: .....

GODKJENT: .....

SELGER: .....

KJØPER: .....

Copyright 2016 JM Norge AS

C:\Users\4715222\Revit\_Local\Myrvoll\_stasjon\_110541\_Hus\_6\_linda.helland@jlm.no.rvt

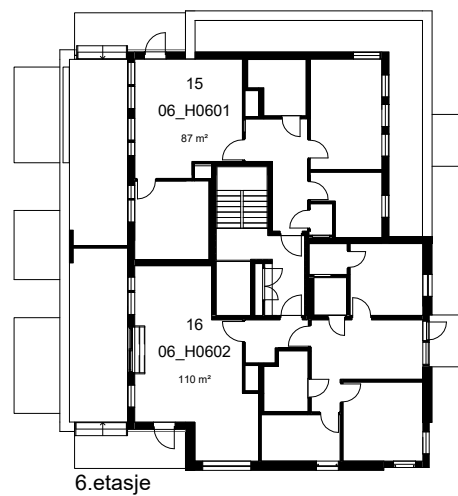
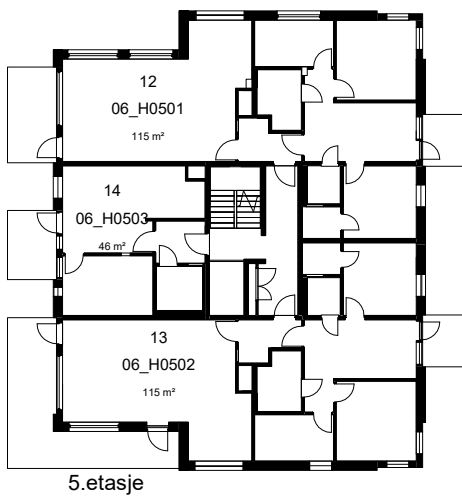
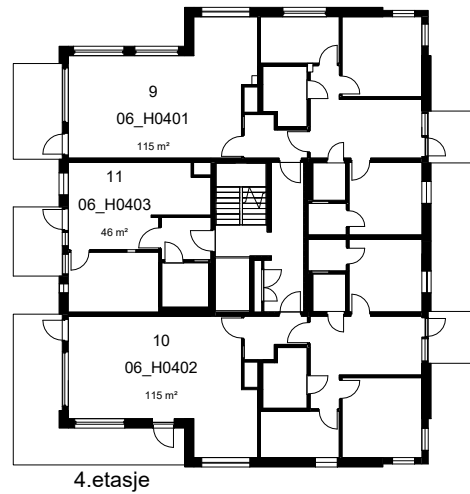
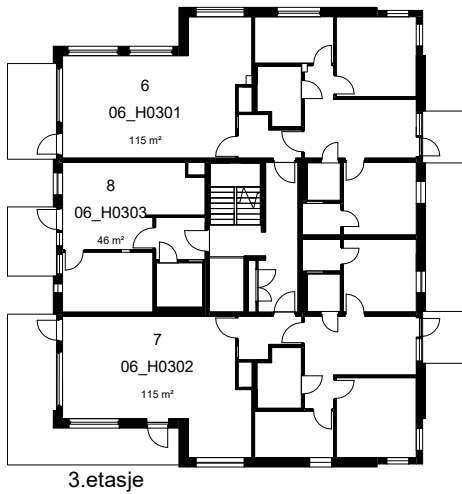
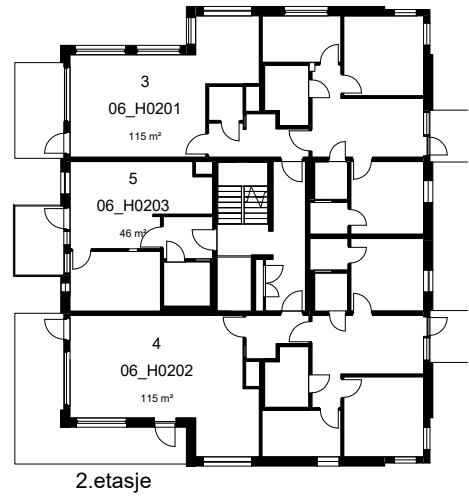
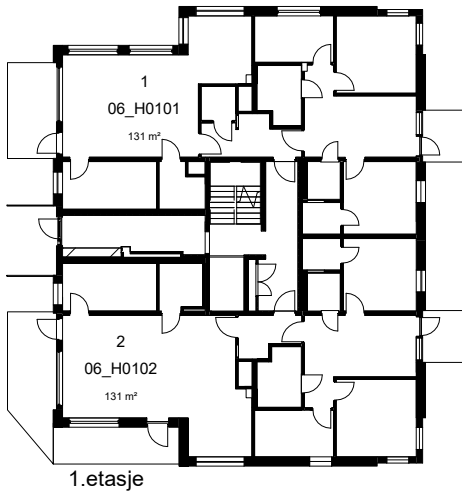

DOKUMENT GYLDIG: .....

GODKJENT: .....

KONTRAKTSDATO: .....

SELGER: .....

KJØPER: .....



TEGNFORKLARING

	GARDEROBE
	SKYVEDØRSGARDEROBE
	KOMFYRTOPP
	KOMFYR
	HØYSKAP MED KOMFYR
	OVERSKAP MED VIFTE
	OPPVASKMASKIN
	HØYSKAP MED KJØL OG FRYS
	TØRKETROMMEL
	VASKEMASKIN
	NEDFORING/ INNKASSING
	NEDFORET HIMLING
	RADIATOR
	FORDELERSKAP FOR BRUKSVANN OG VARME
	SIKRINGSSKAP
	DOBBELT STIKK INNFELT
	ENKEL STIKK INNFELT
	DOBBEL STIKK MED LOKK
	STIKK FOR PLATETOPP MIKOMFYRVAKT
	ENKEL DCL UTTAK VED TAK
	6-VEIS STIKK INNFELT
	ENKEL DCL UTTAK I TAK
	ENPOLT BRYTER
	TOPOLT BRYTER
	DOBBELT ENPOLET BRYTER
	DIMMER
	DOWNLIGHT INNFELT
	SIRKULÆRLAMPE I TAK
	LAMPE PÅ VEGG UTENDØRS
	REGULATOR FOR VARMEKABEL
	VARMEKABEL
	DOBBELT DATAUTTAK VED TV
	LED-LIST UNDER OVERSKAP
	BODARMATUR
	PORTTELEFONAPPARAT
	RINGEKNAPP
	LEDELYS I TAK

08/07/18

DOKUMENT GYLDIG: .....

GODKJENT: .....

KONTRAKTSDATO: .....

SELGER: .....

KJØPER: .....

KONTRAKTSVEDLEGG  
**TORGKVARTALET HUS 6**  
 Leilighetsplan

Seksjonsnr.: 1  
 Leilighetnr.: 06-H0101  
 BRA: 131m<sup>2</sup>  
 P- rom: 118,5m<sup>2</sup>

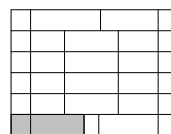
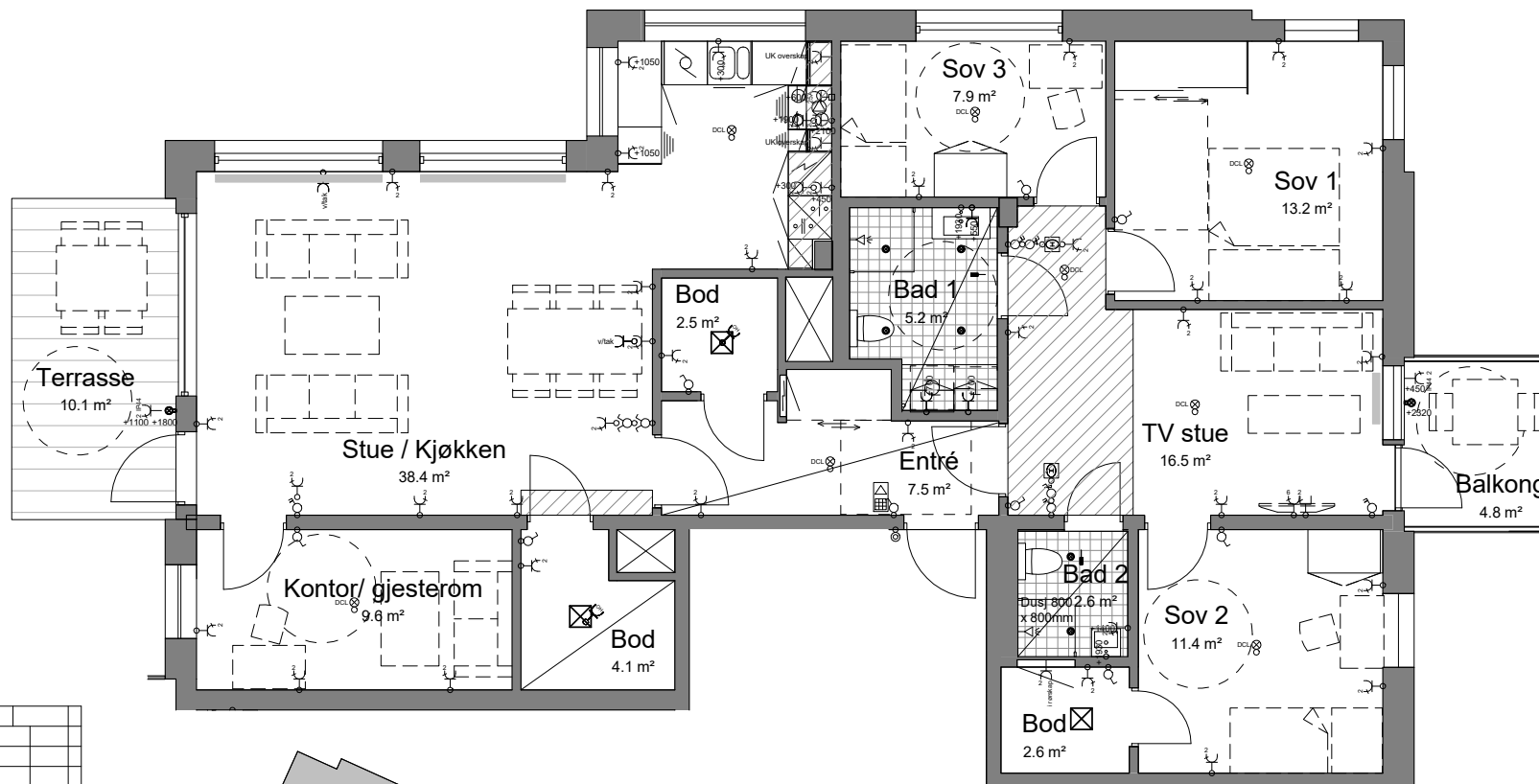

fra tun (nordvest)

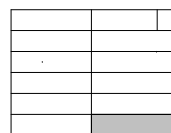

fra dammen (sørøst)

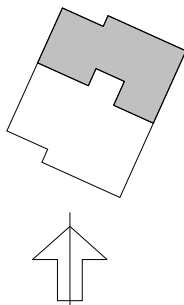

Alt som er stiptet leveres ikke.  
 Plassering inventar er orienterende.  
 Størrelse på radiatorer er ikke bestemt.  
 Plassering av sprinkler og røykvarsler vises ikke.  
 Endelig plassering av el og vvs vil kunne avvike fra tegningene.

07/03/18

DOKUMENT GYLDIG: .....

GODKJENT: .....

KONTRAKTSDATO: .....

SELGER: .....

KJØPER: .....

KONTRAKTSVEDLEGG  
**TORGKVARTALET HUS 6**  
 Leilighetsplan

Seksjonsnr.: 2  
 Leilighetnr.: 06-H0102  
 BRA: 131m2  
 P- rom: 121,5m2

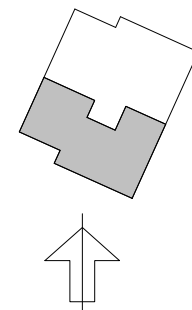
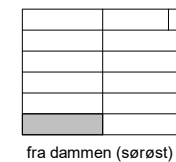
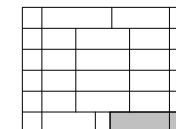
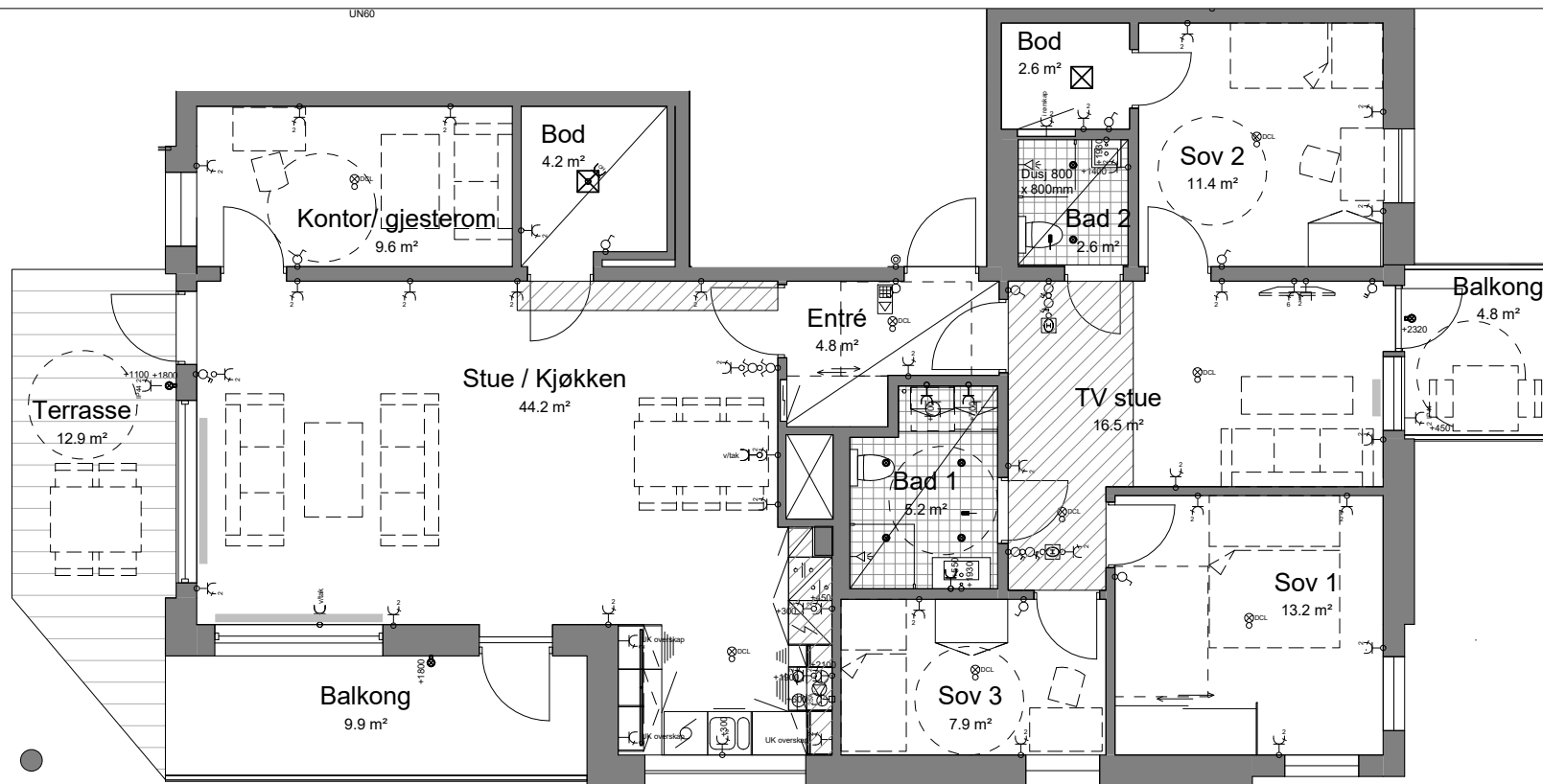

Alt som er stiptet leveres ikke.  
 Plassering inventar er orienterende.  
 Størrelse på radiatorer er ikke bestemt.  
 Plassering av sprinkler og røykvarsler vises ikke.  
 Endelig plassering av el og vvs vil kunne avvike fra tegningene.



DOKUMENT GYLDIG: .....

GODKJENT: .....

KONTRAKTSDATO: .....

SELGER: .....

KJØPER: .....

06/28/18

KONTRAKTSVEDLEGG  
**TORGKVARTALET HUS 6**  
 Leilighetsplan

Seksjonsnr.: 3  
 Leilighetnr.: 06-H0201  
 BRA: 115m2  
 P- rom: 107,5m2

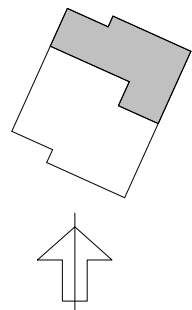
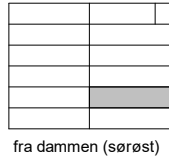
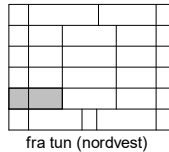
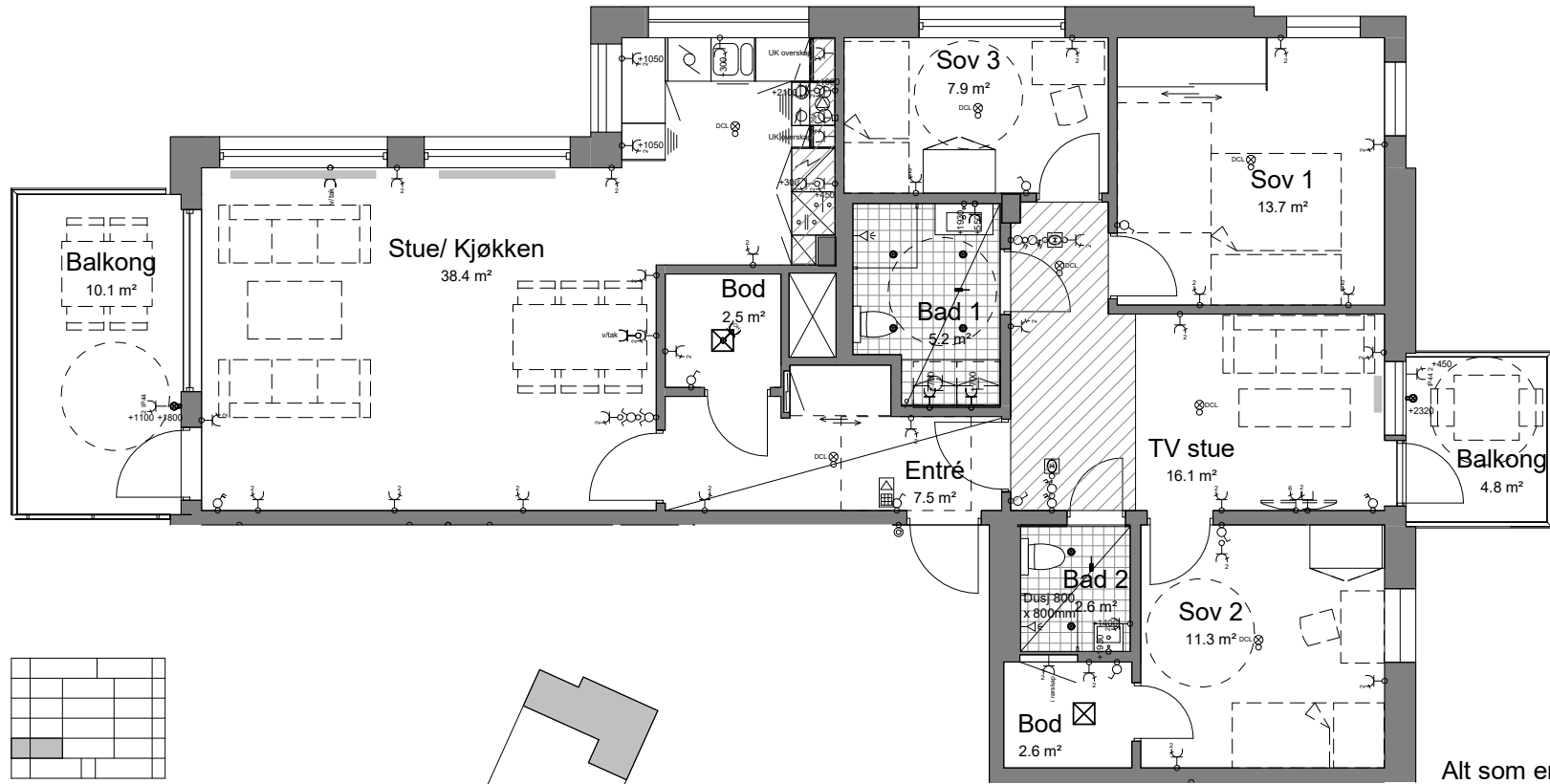

Alt som er stiptet leveres ikke.  
 Plassering inventar er orienterende.  
 Størrelse på radiatorer er ikke bestemt.  
 Plassering av sprinkler og røykvarsler vises ikke.  
 Endelig plassering av el og vvs vil kunne avvike fra tegningene.

06/07/18

DOKUMENT GYLDIG: .....  
 GODKJENT: .....

KONTRAKTSDATO: .....  
 SELGER: .....  
 KJØPER: .....



KONTRAKTSVEDLEGG  
TORGKVARTALET HUS 6  
Leilighetsplan

Seksjonsnr.: 4  
Leilighetnr.: 06-H0202  
BRA: 115m<sup>2</sup>  
P- rom: 111m<sup>2</sup>

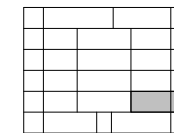
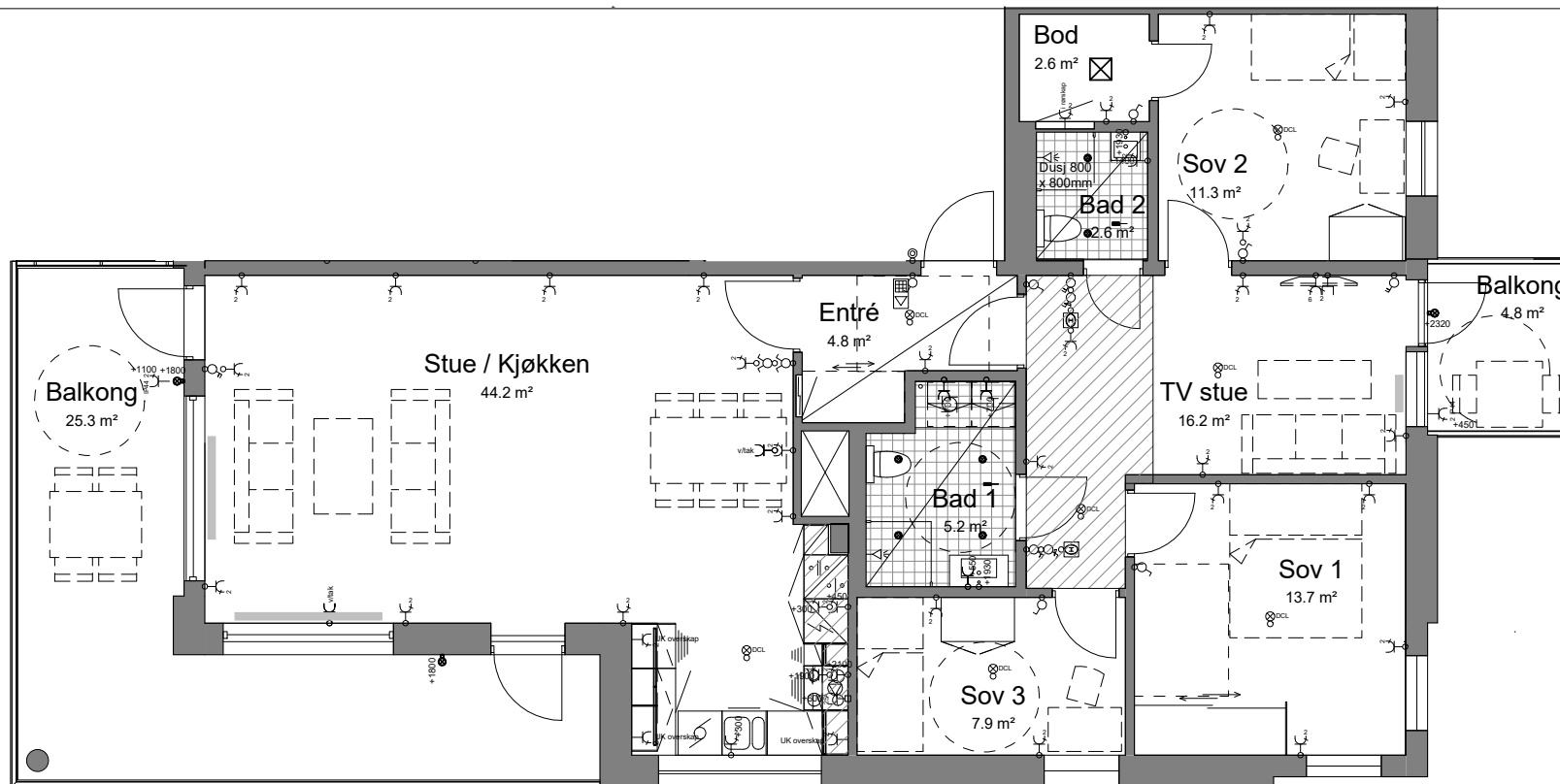

fra tun (nordvest)

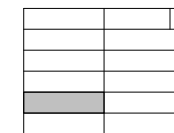

fra dammen (sørøst)

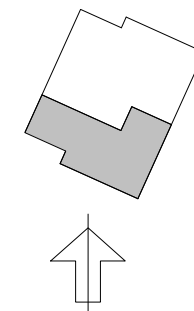

Alt som er stiptet leveres ikke.  
Plassering inventar er orienterende.  
Størrelse på radiatorer er ikke bestemt.  
Plassering av sprinkler og røykvarsler vises ikke.  
Endelig plassering av el og vvs vil kunne avvike fra tegningene.



DOKUMENT GYLDIG: .....

GODKJENT: .....

KONTRAKTSDATO: .....

SELGER: .....

KJØPER: .....

06/28/18



TORGKVARTALET HUS 6

Leilighetsplan

BRA: 46m2

P- rom: 43,5m2

TEGNFORKLARING

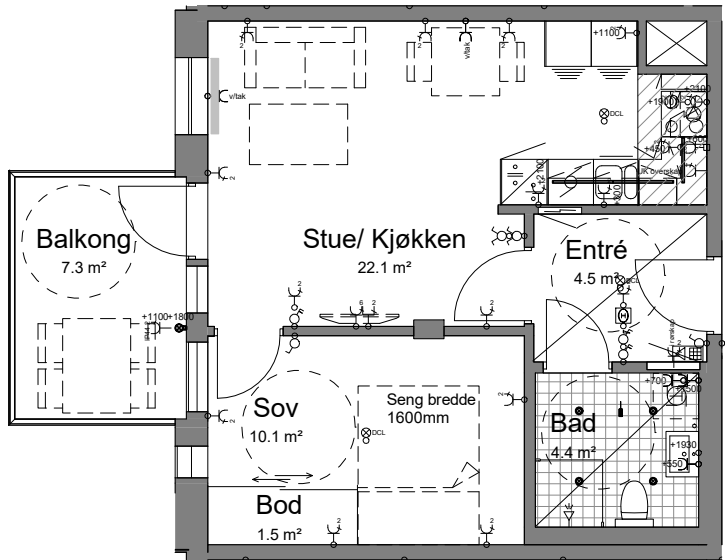

- GARDEROBE
- SKYVEDØRSKLOSETT
- KOMFYRTOPP
- KOMFYR
- HØYSKAP MED KOMFYR
- OVERSKAP MED VIFTE
- OPPVASKMASKIN
- HØYSKAP MED KJØLE OG FRYSE
- TØRKETROMMEL
- VASKEMASKIN
- NEDFORING/ INNKASSING
- NEDFORET HIMLING
- RADIATOR
- FORDELELSKAP FORBRUSVANN OG VARME
- SIKRINGSKAP
- DOBBELT STIKK INNFELT
- ENKEL STIKK INNFELT
- DOBBELT STIKK MED LOKK
- STIKK FOR PLATETOPP MKOMFYRVAKT
- ENKEL DCL UTTAK VED TAK
- 6-VEIS STIKK INNFELT
- ENKEL DCL UTTAK I TAK
- ENPOLT BRYTER
- TOPOLT BRYTER
- DOBBELT ENPOLT BRYTER
- DIMMER
- DOWNLIGHT INNFELT
- SIRKULÆRLAMPE I TAK
- LAMPE PÅ VEGG UTENDØRS
- REGULATOR FOR VARMEKABEL
- VARMEKABEL
- DOBBELT DATAUTTAK VED TV
- LED-LIST UNDER OVERSKAP BODARMATUR
- PORTTELEFONAPPARAT
- RINGEKNAPP
- LEDELSY I TAK

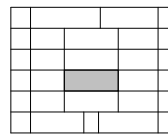
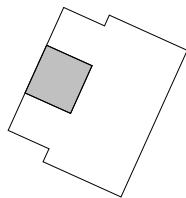

fra tun (nordvest)



Alt som er stiplet leveres ikke.  
 Plassering inventar er orienterende.  
 Størrelse på radiatorer er ikke bestemt.  
 Plassering av sprinkler og røykvarsler vises ikke.  
 Endelig plassering av el og vvs vil kunne avvike fra tegningene.

DOKUMENT GYLDIG: .....

KONTRAKTSDATO: .....

GODKJENT: .....

SELGER: .....

KJØPER: .....

KONTRAKTSVEDLEGG  
TORGKVARTALET HUS 6  
Leilighetsplan

Seksjonsnr.: 6  
Leilighetnr.: 06-H0301  
BRA: 115m<sup>2</sup>  
P- rom: 111m<sup>2</sup>

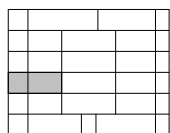
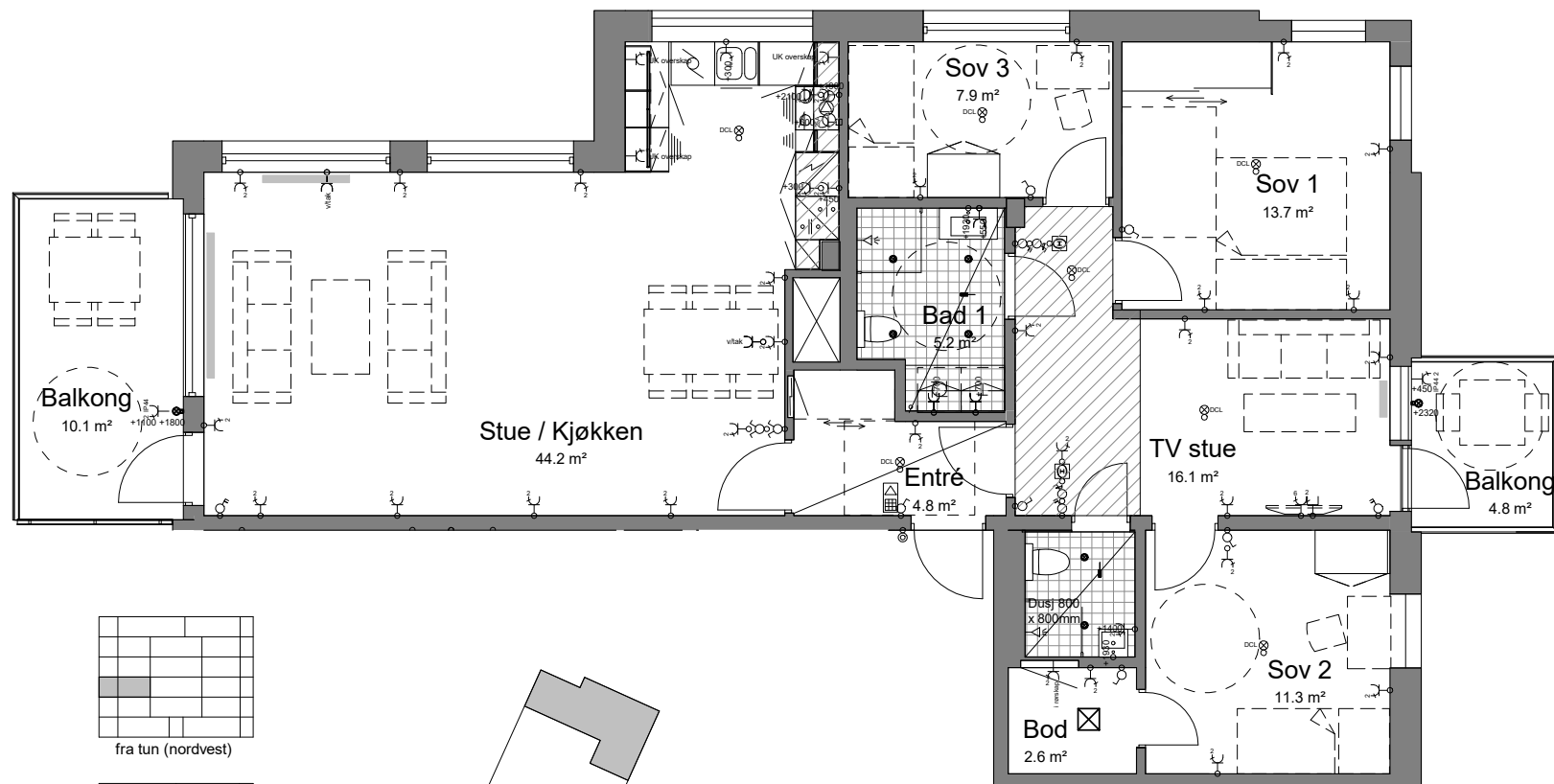

fra tun (nordvest)

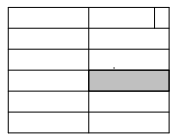

fra dammen (sørøst)

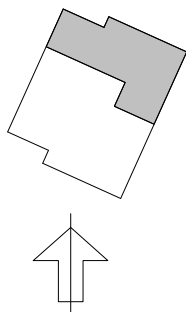

Alt som er stiptet leveres ikke.  
Plassering inventar er orienterende.  
Størrelse på radiatorer er ikke bestemt.  
Plassering av sprinkler og røykvarsler vises ikke.  
Endelig plassering av el og vvs vil kunne avvike fra tegningene.



07/03/18

DOKUMENT GYLDIG: .....

GODKJENT: .....

KONTRAKTSDATO: .....

SELGER: .....

KJØPER: .....

KONTRAKTSVEDLEGG  
TORGKVARTALET HUS 6  
Leilighetsplan

Seksjonsnr.: 7  
Leilighetnr.: 06-H0302  
BRA: 115m2  
P- rom: 111m2

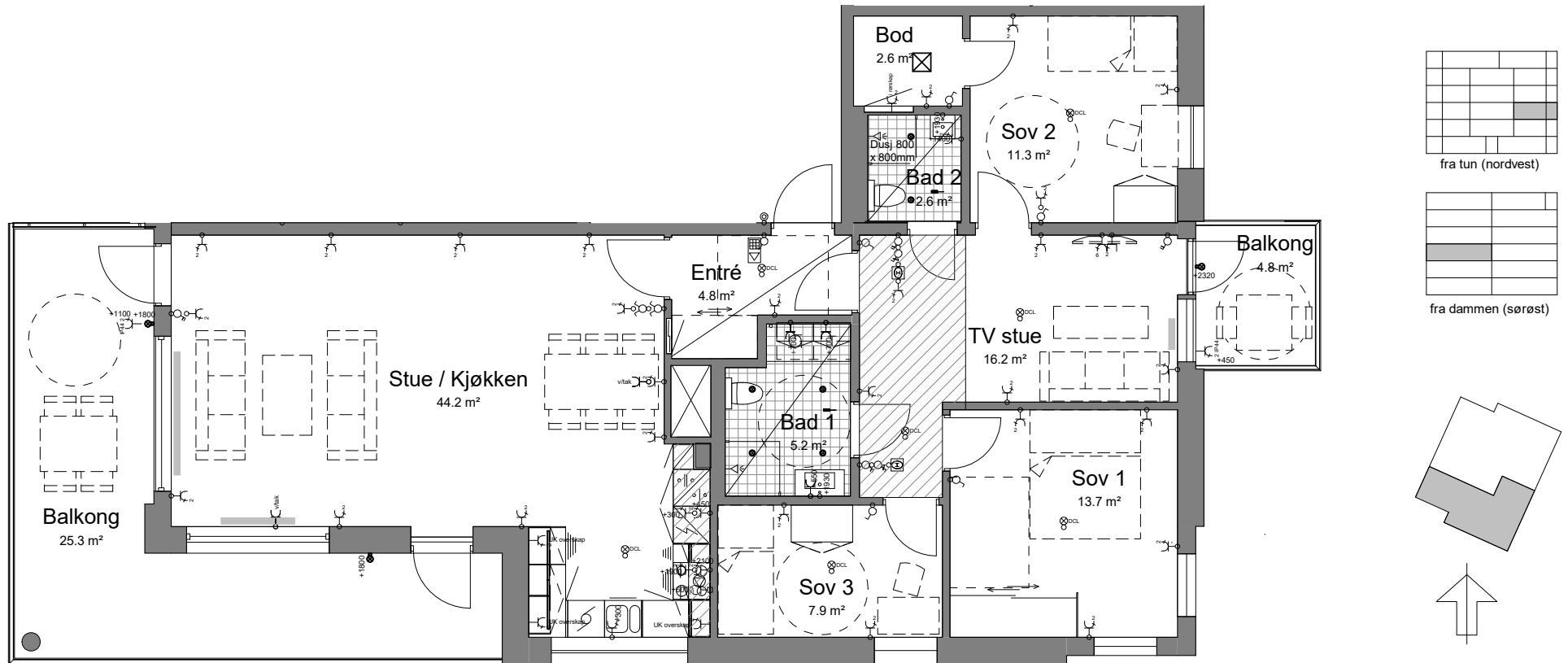

Alt som er stiptet leveres ikke.  
Plassering inventar er orienterende.  
Størrelse på radiatorer er ikke bestemt.  
Plassering av sprinkler og røykvarsler vises ikke.  
Endelig plassering av el og vvs vil kunne avvike fra tegningene.

DOKUMENT GYLDIG: .....

GODKJENT: .....

KONTRAKTSDATO: .....

SELGER: .....

KJØPER: .....





































07/03/18

KONTRAKTSVEDLEGG  
**TORGKVARTALET HUS 6**  
 Leilighetsplan

Seksjonsnr.: 8  
 Leilighetnr.: 06-H0303  
 BRA: 46m2  
 P- rom: 43,5m2



TEGNFORKLARING

-  GARDEROBE
-  SKYVEDØRS GARDEROBE
-  KOMFYRTOPP
-  KOMFYR
-  HØYSKAP MED KOMFYR
-  OVERSKAP MED VIFTE
-  OPPVASKMASKIN
-  HØYSKAP MED KJØLL OG FRYSS
-  TØRKETROMMEL
-  VASKEMASKIN
-  NEDFORING/ INNKASSING
-  NEDFORET HIMLING
-  RADIATOR
-  FORDELESKAPP FOR BRUKSVANN OG VARME
-  SIKRINGSSKAPP
-  DOBBELT STIKK INNFELT
-  ENKEL STIKK INNFELT
-  DOBBEL STIKK MED LOKK
-  STIKK FOR PLATETOPP MIKOMFYRVAKT
-  ENKEL DCL UTТАK VED TAK
-  6-VEIS STIKK INNFELT
-  ENKEL DCL UTТАK I TAK
-  ENPOLT BRYTER
-  TOPOLT BRYTER
-  DOBBELT ENPOLET BRYTER
-  DIMMER
-  DOWNLIGHT INNFELT
-  SIRKULÆRLAMPE I TAK
-  LAMPE PÅ VEGG UTENDØRS
-  REGULATOR FOR VARMEKABEL
-  VARMEKABEL
-  DOBBELT DATAUTTAK VED TV
-  LED-LIST UNDER OVERSKAP
-  BODARMATUR
-  PORTTELEFONAPPARAT
-  RINGEKNAPP
-  LEDEHYS I TAK

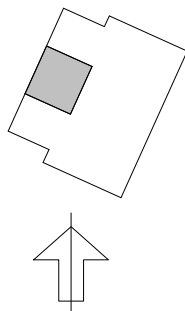
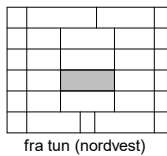
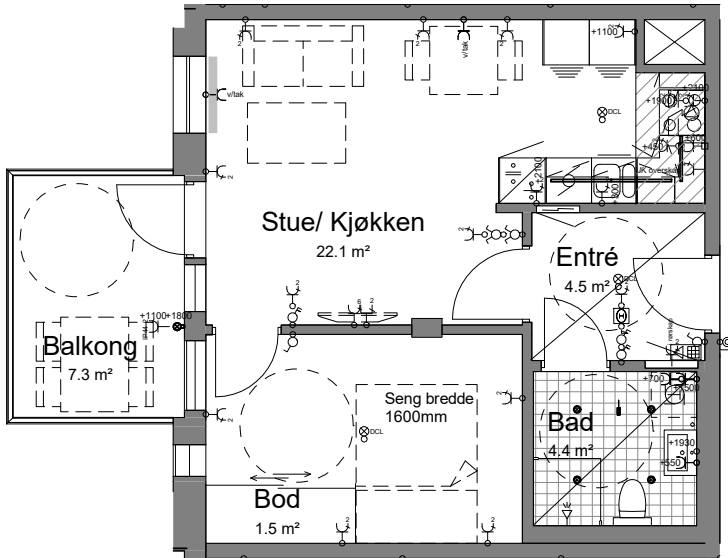

Alt som er stiplet leveres ikke.  
 Plassering inventar er orienterende.  
 Størrelse på radiatorer er ikke bestemt.  
 Plassering av sprinkler og røykvarsler vises ikke.  
 Endelig plassering av el og vvs vil kunne avvike fra tegningene.



DOKUMENT GYLDIG: .....

KONTRAKTSDATO: .....

GODKJENT: .....

SELGER: .....

KJØPER: .....

KONTRAKTSVEDLEGG  
**TORGKVARTALET HUS 6**  
 Leilighetsplan

Seksjonsnr.: 9  
 Leilighetnr.: 06-H0401  
 BRA: 115m<sup>2</sup>  
 P- rom: 111m<sup>2</sup>

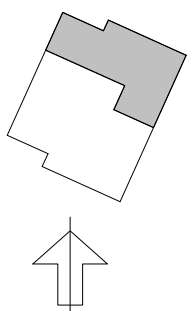
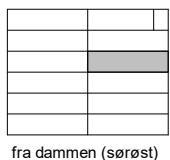
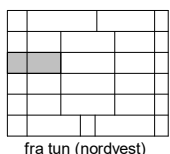
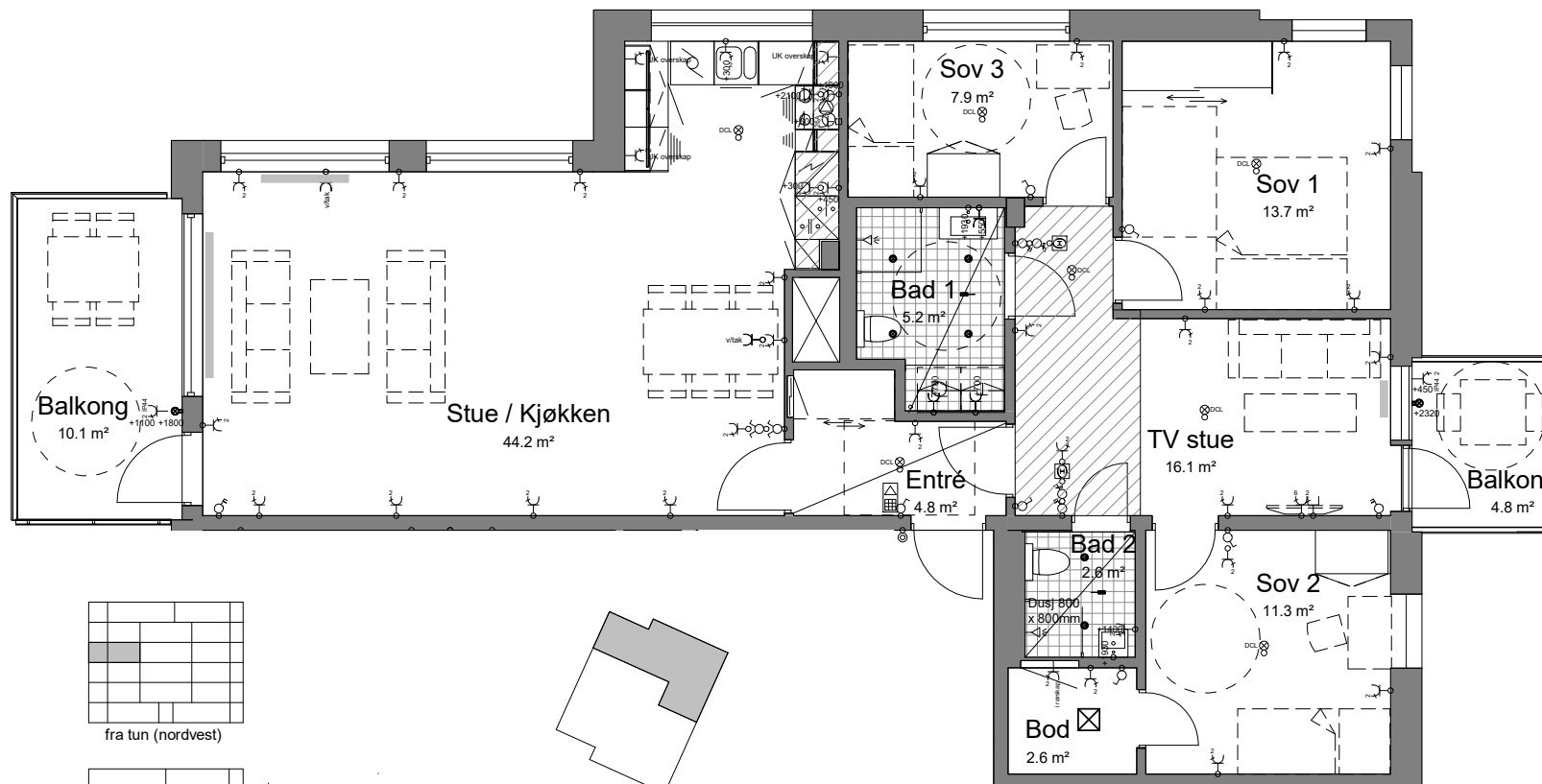

Alt som er stiptet leveres ikke.  
 Plassering inventar er orienterende.  
 Størrelse på radiatorer er ikke bestemt.  
 Plassering av sprinkler og røykvarsler vises ikke.  
 Endelig plassering av el og vvs vil kunne avvike fra tegningene.

07/03/18

DOKUMENT GYLDIG: .....

GODKJENT: .....

KONTRAKTSDATO: .....

SELGER: .....

KJØPER: .....

KONTRAKTSVEDLEGG  
TORGKVARTALET HUS 6  
Leilighetsplan

Seksjonsnr.: 10  
Leilighetnr.: 06-H0402  
BRA: 115m2  
P- rom: 111m2

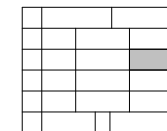
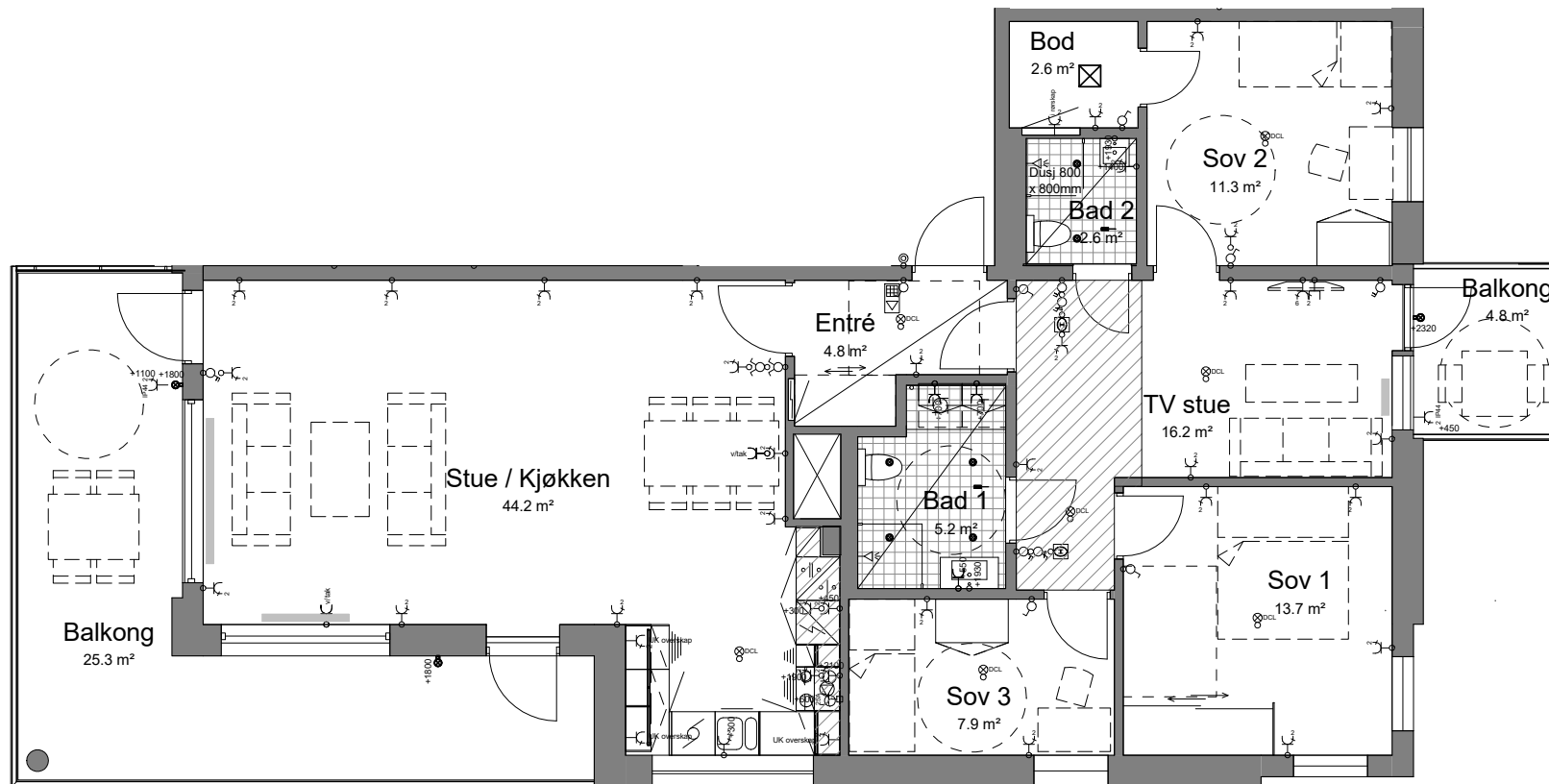

fra tun (nordvest)

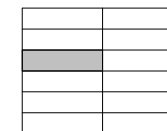

fra dammen (sørøst)

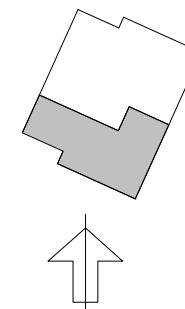

Alt som er stiptet leveres ikke.  
Plassering inventar er orienterende.  
Størrelse på radiatorer er ikke bestemt.  
Plassering av sprinkler og røykvarsler vises ikke.  
Endelig plassering av el og vvs vil kunne avvike fra tegningene.



DOKUMENT GYLDIG: .....

GODKJENT: .....

KONTRAKTSDATO: .....

SELGER: .....

KJØPER: .....





































07/05/18

KONTRAKTSVEDLEGG  
**TORGKVARTALET HUS 6**  
 Leilighetsplan

Seksjonsnr.: 11  
 Leilighetnr.: 06-H0403  
 BRA: 46m2  
 P- rom: 43,5m2



TEGNFORKLARING

-  GARDEROBE
-  SKYVEDØRSGARDEROBE
-  KOMFYRTOPP
-  KOMFYR
-  HØYSKAP MED KOMFYR
-  OVERSKAP MED VIFTE
-  OPPVASKMASKIN
-  HØYSKAP MED KJØLL OG FRYSS
-  TØRKETROMMEL
-  VASKEMASKIN
-  NEDFORING/ INNKASSING
-  NEDFORET HIMLING
-  RADIATOR
-  FORDELERSKAP FOR BRUKSVANN OG VARME
-  SIKRINGSSKAP
-  DOBBELT STIKK INNFELT
-  ENKEL STIKK INNFELT
-  DOBBELT STIKK MED LOKK
-  STIKK FOR PLATETOPP MKOFYRVAKT
-  ENKEL DCL UTTAK VED TAK
-  6-VEIS STIKK INNFELT
-  ENKEL DCL UTTAK I TAK
-  ENPOLT BRYTER
-  TOPOLT BRYTER
-  DOBBELT ENPOLET BRYTER
-  DIMMER
-  DOWNLIGHT INNFELT
-  SIRKULÆRLAMPE I TAK
-  LAMPE PÅ VEGG UTENDØRS
-  REGULATOR FOR VARMEKABEL
-  VARMEKABEL
-  DOBBELT DATAUTTAK VED TV
-  LED-LIST UNDER OVERSKAP BODARMATUR
-  PORTTELEFONAPPARAT
-  RINGEKNAPP
-  LELELYS I TAK

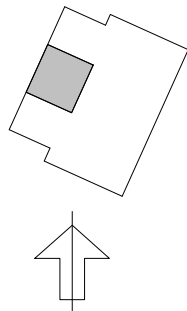
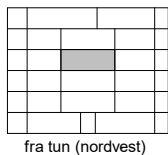
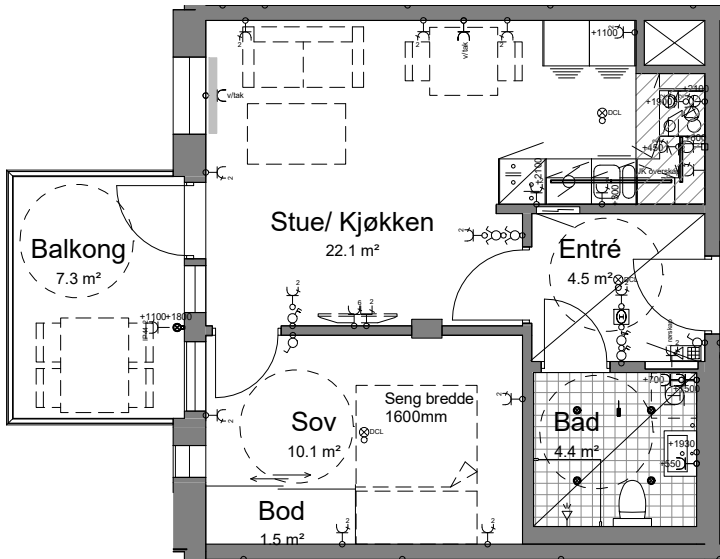

Alt som er stiplet leveres ikke.  
 Plassering inventar er orienterende.  
 Størrelse på radiatorer er ikke bestemt.  
 Plassering av sprinkler og røykvarsler vises ikke.  
 Endelig plassering av el og vvs vil kunne avvike fra tegningene.



DOKUMENT GYLDIG: .....  
 GODKJENT: .....

KONTRAKTSDATO: .....  
 SELGER: .....  
 KJØPER: .....



KONTRAKTSVEDLEGG  
TORGKVARTALET HUS 6  
Leilighetsplan

Seksjonsnr.: 12  
Leilighetnr.: 06-H0501  
BRA: 115m2  
P- rom: 111m2

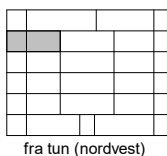
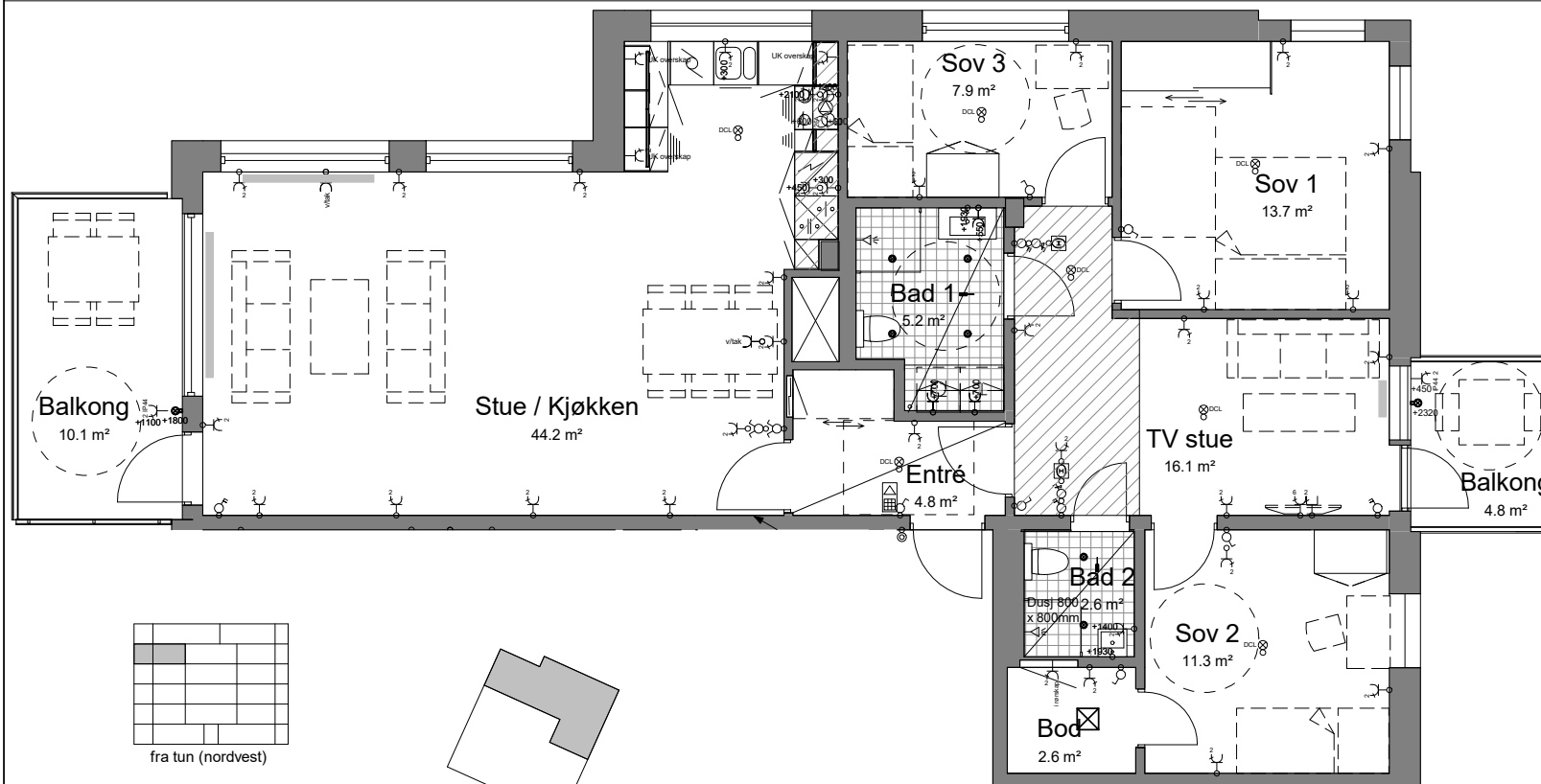

fra tun (nordvest)

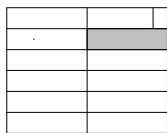

fra dammen (sørøst)

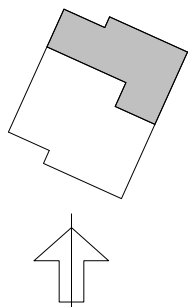

Alt som er stiptet leveres ikke.  
Plassering inventar er orienterende.  
Størrelse på radiatorer er ikke bestemt.  
Plassering av sprinkler og røykvarsler vises ikke.  
Endelig plassering av el og vvs vil kunne avvike fra tegningene.

07/03/18

DOKUMENT GYLDIG: .....

GODKJENT: .....

KONTRAKTSDATO: .....

SELGER: .....

KJØPER: .....

KONTRAKTSVEDLEGG  
TORGKVARTALET HUS 6  
Leilighetsplan

Seksjonsnr.: 13  
Leilighetnr.: 06-H0502  
BRA: 115m2  
P- rom: 111m2

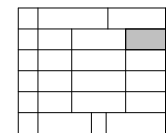
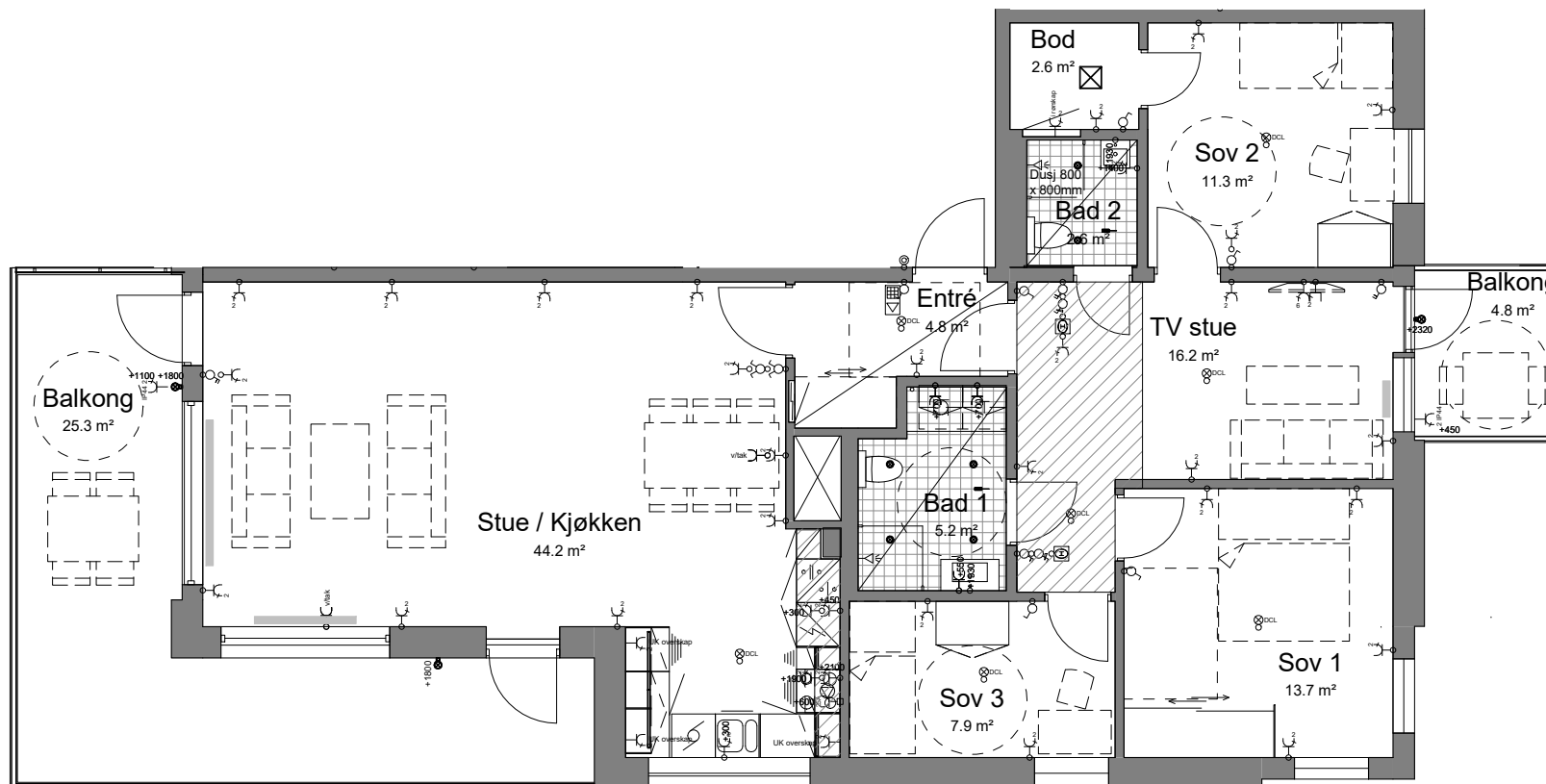

fra tun (nordvest)

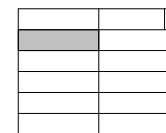

fra dammen (sørøst)

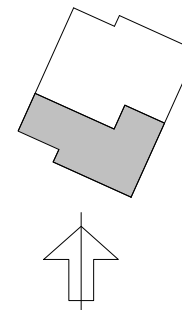

Alt som er stiptet leveres ikke.  
Plassering inventar er orienterende.  
Størrelse på radiatorer er ikke bestemt.  
Plassering av sprinkler og røykvarsler vises ikke.  
Endelig plassering av el og vvs vil kunne avvike fra tegningene.



DOKUMENT GYLDIG: .....

GODKJENT: .....

KONTRAKTSDATO: .....

SELGER: .....

KJØPER: .....





































07/03/18

KONTRAKTSVEDLEGG  
**TORGKVARTALET HUS 6**  
 Leilighetsplan

Seksjonsnr.: 14  
 Leilighetnr.: 06-H0503  
 BRA: 46m2  
 P- rom: 43,5m2



TEGNFORKLARING

-  GARDEROBE
-  SKYVEDØRSGARDEROBE
-  KOMFYRTEPP
-  KOMFYR
-  HØYSKAP MED KOMFYR
-  OVERSKAP MED VIFTE
-  OPPVASKMASKIN
-  HØYSKAP MED KJØLE OG FRYSE
-  TØRKETROMMEL
-  VASKEMASKIN
-  NEDFORING/ INNKASSING
-  NEDFORET HIMLING
-  RADIATOR
-  FORDELERSKAP FOR BRUKSVANN OG VARME
-  SIKRINGSSKAP
-  DOBBELT STIKK INNFELT
-  ENKEL STIKK INNFELT
-  DOBBELT STIKK MED LOKK
-  STIKK FOR PLATETOPP / MIKOMFYRVAKT
-  ENKEL DCL UTTAK VED TAK
-  6-VEIS STIKK INNFELT
-  ENKEL DCL UTTAK I TAK
-  ENPOLT BRYTER
-  TOPOLT BRYTER
-  DOBBELT ENPOLT BRYTER
-  DIMMER
-  DOWNLIGHT INNFELT
-  SIRKULÆRLAMPE I TAK
-  LAMPE PÅ VEGG UTENDØRS
-  REGULATOR FOR VARMEKABEL
-  VARMEKABEL
-  DOBBELT DATAUTTAK VED TV
-  LED-LIST UNDER OVERSKAP BODARMATUR
-  PORTTELEFONAPPARAT
-  RINGEKNAPP
-  LEDELYS I TAK

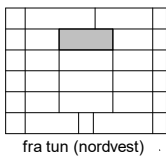
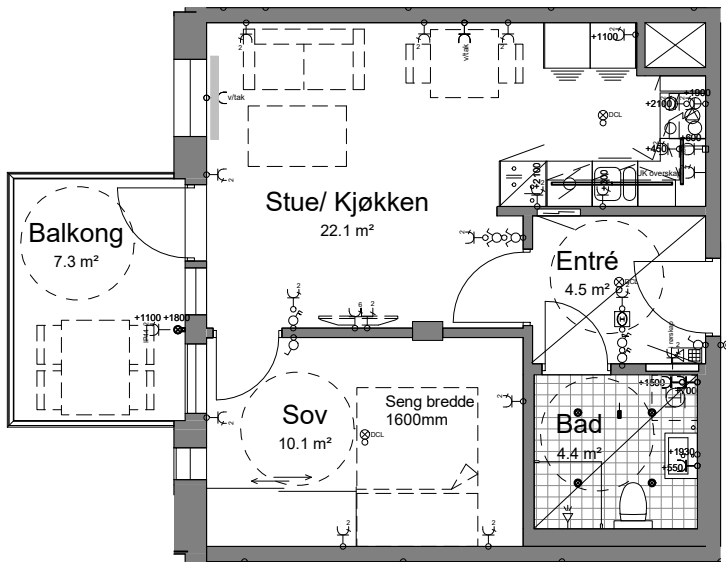

fra tun (nordvest)

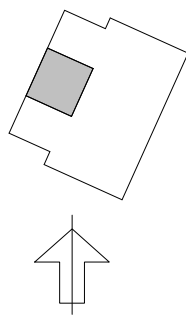

Alt som er stiplet leveres ikke.  
 Plassering inventar er orienterende.  
 Størrelse på radiatorer er ikke bestemt.  
 Plassering av sprinkler og røykvarsler vises ikke.  
 Endelig plassering av el og vvs vil kunne avvike fra tegningene.



DOKUMENT GYLDIG: .....

KONTRAKTSDATO: .....

GODKJENT: .....

SELGER: .....

KJØPER: .....

07/03/18

KONTRAKTSVEDLEGG  
TORGKVARTALET HUS 6  
Leilighetsplan

Seksjonsnr.: 15  
Leilighetnr.: 06-H0601  
BRA: 87m<sup>2</sup>  
P- rom: 83m<sup>2</sup>

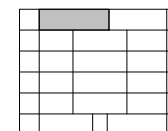
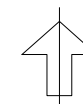
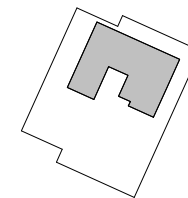

fra tun (nordvest)

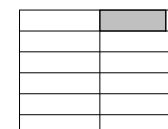

fra dammen (sørøst)

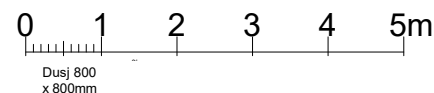
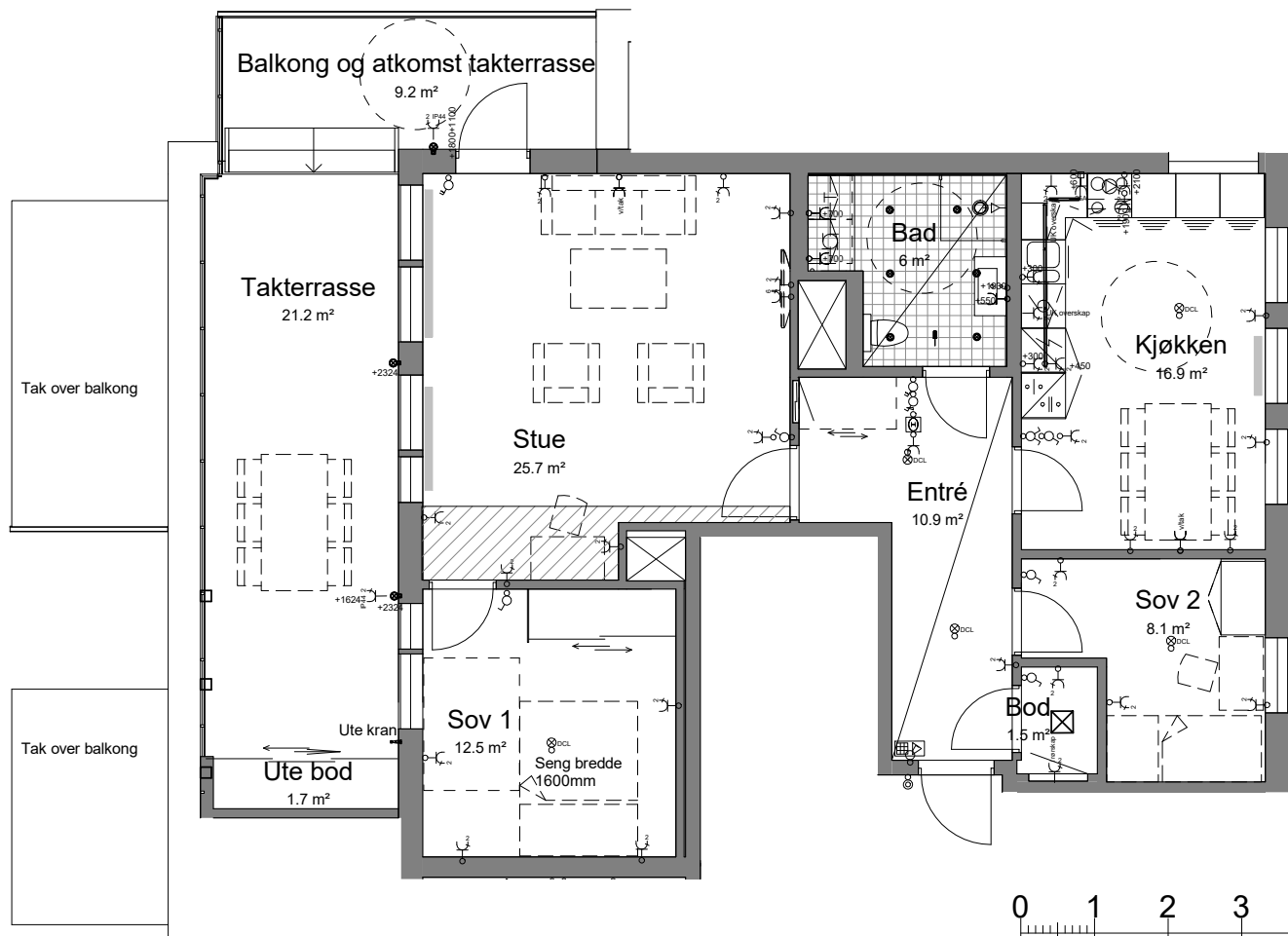

Alt som er stiptet leveres ikke.  
Plassering inventar er orienterende.  
Størrelse på radiatorer er ikke bestemt.  
Plassering av sprinkler og røykvarsler vises ikke.  
Endelig plassering av el og vvs vil kunne avvike fra tegningene.

08/07/18

DOKUMENT GYLDIG: .....

GODKJENT: .....

KONTRAKTSDATO: .....

SELGER: .....

KJØPER: .....

KONTRAKTSVEDLEGG  
**TORGKVARTALET HUS 6**

Leilighetsplan

Seksjonsnr.: 16  
 Leilighetnr.: 06-H0602  
 BRA: 110m2  
 P- rom: 105m2

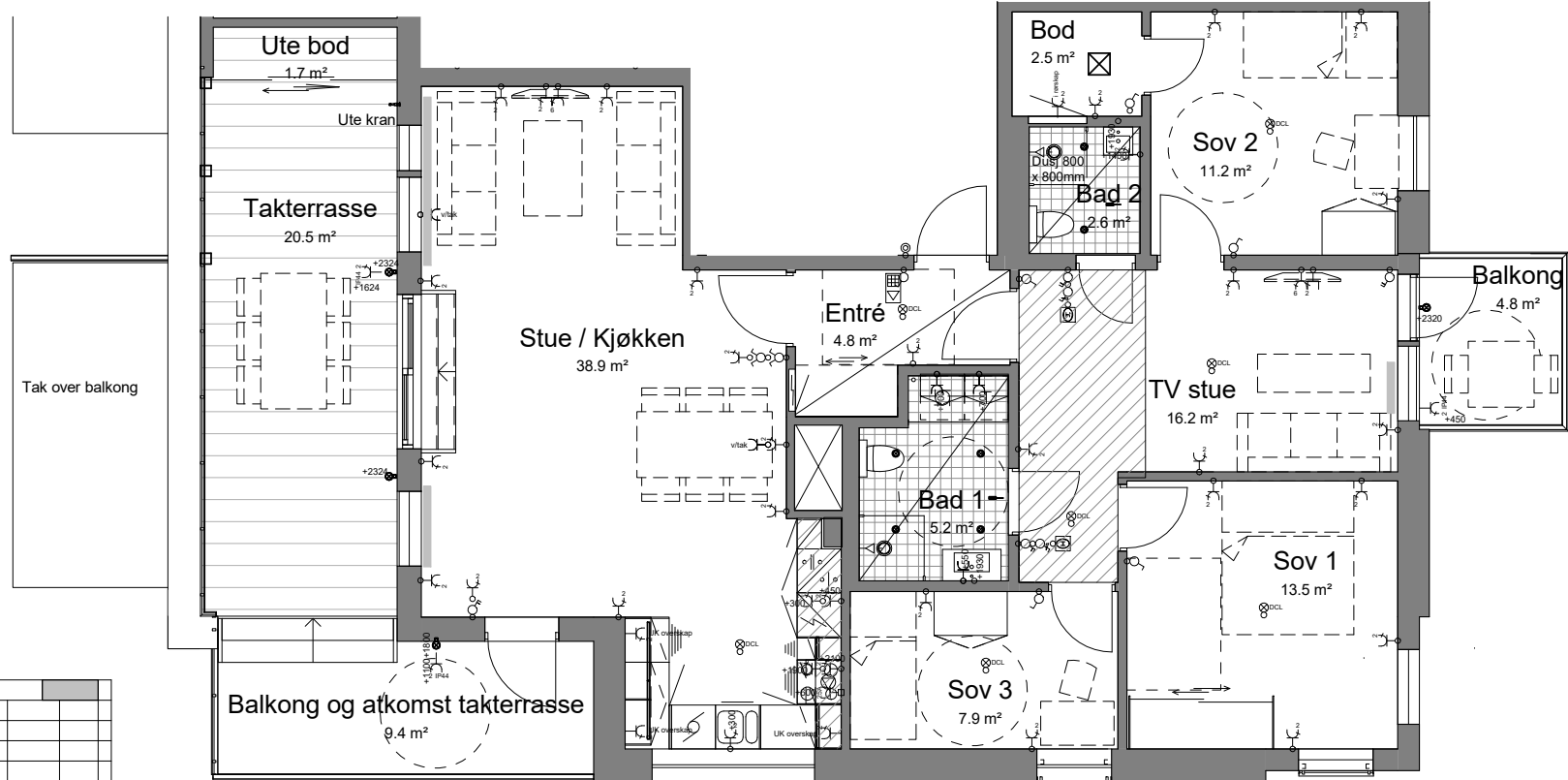

Tak over balkong

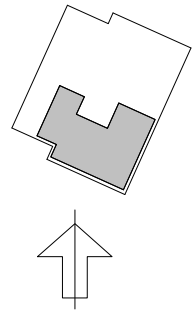
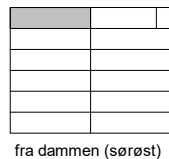
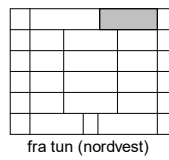

Alt som er stiptet leveres ikke.  
 Plassering inventar er orienterende.  
 Størrelse på radiatorer er ikke bestemt.  
 Plassering av sprinkler og røykvarsler vises ikke.  
 Endelig plassering av el og vvs vil kunne avvike fra tegningene.



DOKUMENT GYLDIG: .....  
 GODKJENT: .....

KONTRAKTSDATO: .....  
 SELGER: .....  
 KJØPER: .....

08/07/18